



MEMBERS NEWS LETTER

VOLUME 1 ISSUE 2 NEWSLETTER DATE 18TH FEBRUARY 2010

LEAD STORY HEADLINE

THE SHOW IS ON

It was confirmed this week that the venue for the Caldicot Castle Classic car show is ok. The date set is the 4th July 2010.

We now need sponsors and ideas to take us forward. A good dose of sunshine will help.

PHIL RE-SHUFFLES HIS COMMITTEE

Due to the high volume of work that the committee has, Phil has decided to delegate certain tasks to his team.

New committee member Brian will be responsible for writing the script for the MGOC magazine, Lorraine and Wayne will also be involved in the process.

Kingsley is responsible for all the clubs equipment.

Lorraine will coordinate all issues regarding the club and writing the monthly Members News letter.

Lester becomes the clubs technical adviser.

Club Holiday 2010

It is now time to make up our minds where this years holiday will be.

Some suggestions are:-

North Wales

Return trip to The Isle of Wight

If anyone has any suggestions please see Wayne or Philip

Stag Supreme

Everybody knows what its like to be parked next to Phil at the shows, bees around a jam pot springs to mind.

However there's now new kids on the block, and that's Tony and Angie with their Triumph Stag. It has more chrome than a Harley Davidson, and its going to attract the Queen bee of the onlookers, you will certainly need your shades.

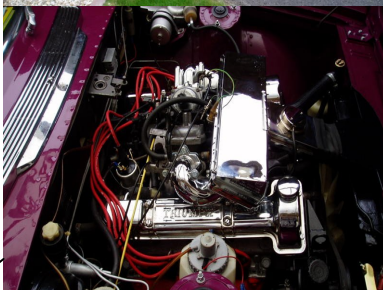

BARGAIN BASEMENT

MGB TOW BAR. SEE PHIL

CLUB SHOWS

21ST FEBRUARY, SUNDAY LUNCH @ THE SEAVIEW HOTEL PORTHCAWL

28TH MARCH BARRY FISH & CHIP RUN TO BE ARRANGED

18TH APRIL THE THREE COUNTIES SHOWGROUND MALVERN £3 PER CAR. LET WAYNE KNOW BY MARCH CLUB NIGHT

CLUB NIGHT

KINGSLEY WILL GIVE A SHORT TALK ON HOW TO USE THE CLUB WALKY TALKIES

TIP OF THE MONTH FIT AN INLINE FUSE IN THE IGNITION LINE

TECHNICAL TYPICAL OVERDRIVE CIRCUIT

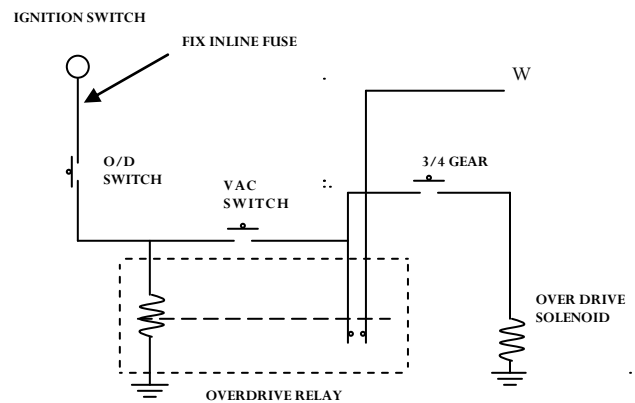

Lorraine and Richard visit MGOC at Swavesey.

The journey should have taken us 45 minutes as we were staying with our son in Peterborough, unfortunately there was a diversion on the A14 which took us 20 miles out of our way. As you enter the shop there are 5 beautiful cars on display, a TC belonging to the owner, a RV8, MGB, TF and a MG V8 they all looked as if they just came out of a new car showroom. Lorraine talked to the office staff about insurance while Richard looked round the shop, with so much to see he actually forgot to get the part he required, however he did buy a rather nice water-proof coat.

Chairman

Philip Watkins
01495 200493

Treasurer

Tony Newton
01291 645786

Events Organiser

Wayne Stedman
01633 413775

Secretary

Lorraine Gwilliam
02920 861719

General Committee

Kingsley Gregory
01633 273434

Lester Burns
07785226849

Brian Powel

02920 860060